

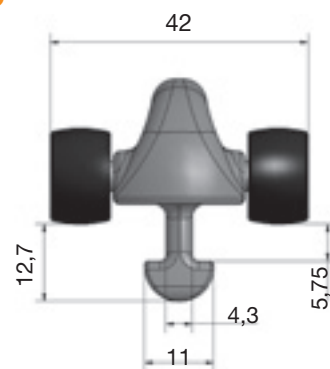

PRESSURE ABSORBING SLIDES

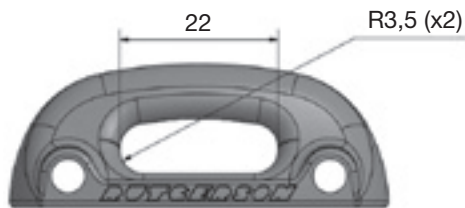

1525-11

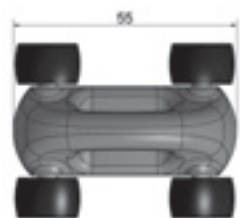
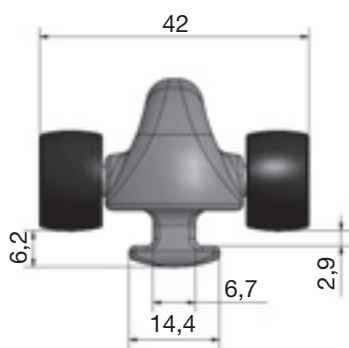

1525-16

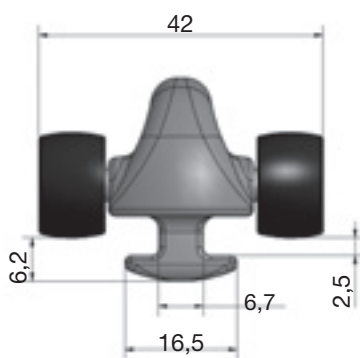

1525-19

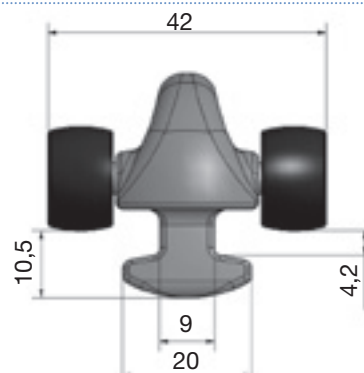

1525-20

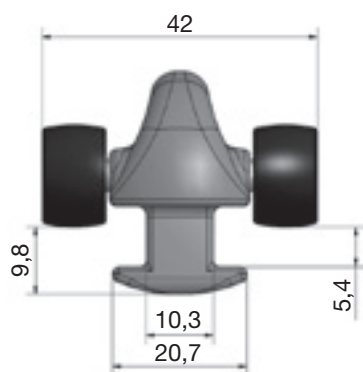

1525-23

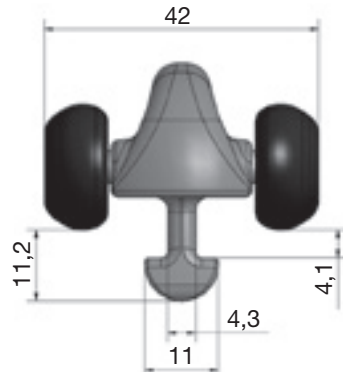

1526-11

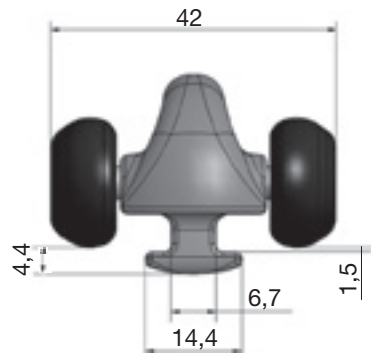

1526-16

Part no	Product description	Wheel Ø [mm]	Recommended fitting	Packed per
PRESSURE ABSORBING SLIDES				
1525-11	Pressure absorbing slide 11mm	15,5	1490, 1490G or Webbing	10
1525-16	Pressure absorbing slide 16mm	15,5	1490, 1490G or Webbing	10
1525-19	Pressure absorbing slide 19mm	15,5	1490, 1490G or Webbing	10
1525-20	Pressure absorbing slide 20mm	15,5	1490, 1490G or Webbing	10
1525-23	Pressure absorbing slide 23mm	15,5	1490, 1490G or Webbing	10
1526-11	Pressure absorbing slide 11mm (big wheels)	19,5	1490, 1490G or Webbing	10
1526-16	Pressure absorbing slide 16mm (big wheels)	19,5	1490, 1490G or Webbing	10

General tolerances for all dimensions equals $\pm 0,5$ mm

BATTCARS

The RutgerSON Battcar solution has proven to be a winner for sailors on all oceans and in all environments. Available for a wide variety of mast applications, this fullbatten car makes the mainsail safer and simpler to handle and trim whilst sailing by requiring minimum maintenance, and is easy to hoist and lower.

All RutgerSON Battcars have a tolerance of 0,5mm.

Battcar general dimensions

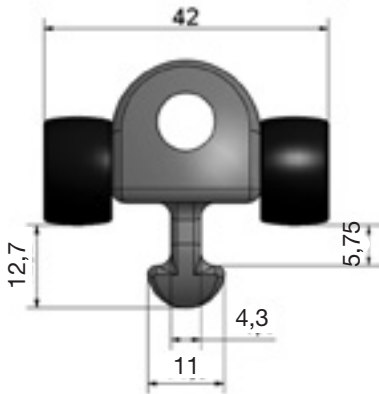

Body
1530-11-XX & 1535-11-XX

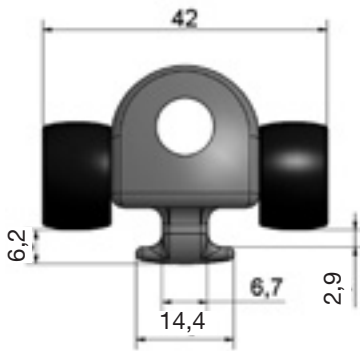

Body
1530-16-XX

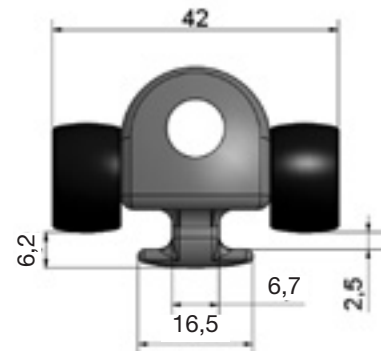

Body
1530-19-XX

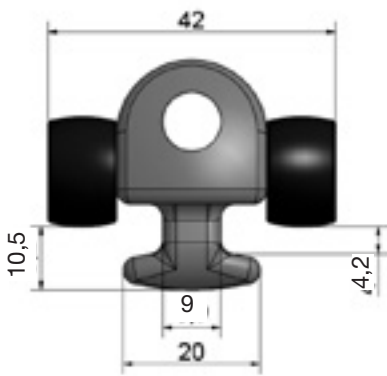

Body
1530-20-XX & 1535-20-XX

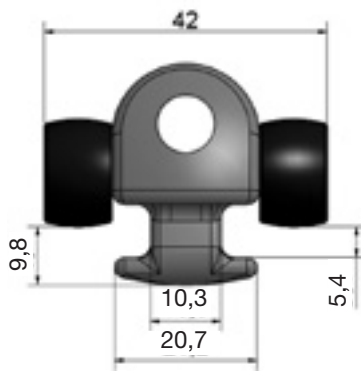

Body
1530-23-XX & 1535-23-XX

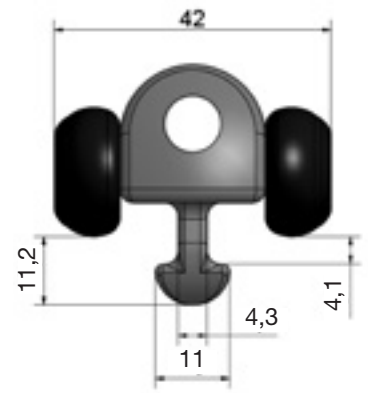

Body
1531-11-XX & 1536-11-XX

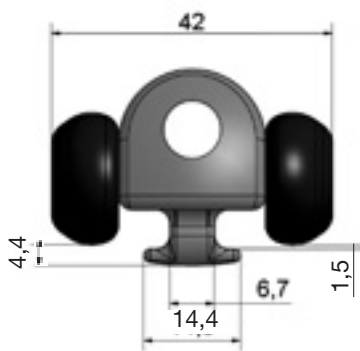

Body
1531-16-XX & 1536-16-XX

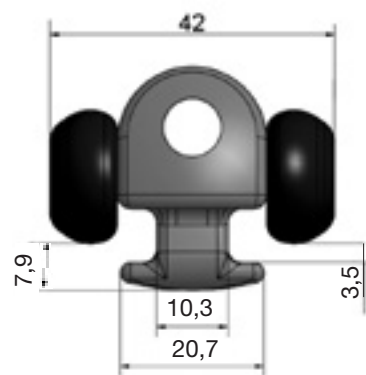

Body
1531-23-XX & 1536-23-XX

Please see page 32 for help guide and mast selection guide



Pressure absorbing Slide & Battcar Mast Selection Guide

		Rutgerson Battcar ref # →						
		1525-11 1530-11-XX 1535-11-XX	1525-16 1530-16-XX	1525-19 1530-19-XX	1525-20 1530-20-XX	1525-23 1530-23-XX 1535-23-XX	1526-11 1531-11-XX 1536-11-XX	1528-23 1540-23-XX
Mast Supplier ref #	Equivalent Holt Allen		HA89	HA90		HA91		
	Sparcraft	F135, F195, F305, F385, F460, I620, S622, I830, S830				NG60, NG70, NG80, NG86, F580, F740, F1060, F1395, S1630, S2100, F2390, F3360, F4600	F35, F50, F67, F78, F101, S137, S180, S260, S330, IMS80, IMS256	NG60, NG70, NG80, NG86, NG105, F580, F740, F1060, F1395, F2390, F3360, F4600
	Seldén	1335 ¹⁾			C156, C175, C193, C211, C227, C245, C264, C285, C304			
	John Mast	135D, 148D, 150D, 165D, 167D, 185D, 186D, 208D, 222D, 245D, 280D, 305D, 335D				220E, 262E, 290E	150E, 116E, 125E	220E, 262E, 290E
	Z Spars	Z301, Z351, Z380, Z401, Z501, Z531, Z601, Z602, Z701, Z702				Z902, Z1001, Z1250, Z1400	Z170, Z190, Z230, Z265	Z1001, Z1250, Z1400
	Soromap	NF200, NF270, NF350, NF430, NF540, NF710, NF1410						

Note: For application in monohull mainsails >50m² (592sq ft.) use the 23 mm High Load Battcar versions with reference no 1535-23-XX. It is also mandatory to apply all Rutgerson battcars with the assembly screw pointing upwards in the mast gate. For mainsails >70 m² (753sq ft.) use the Limousine battcar 1540-23-XX.

1) If the Seldén mast is equipped with a sail entry gate with a cassette with tongue and rubber spring pad, it has to be converted to a track gate insert for fullbatten sails (Seldén part no 505-516-01, 505-524-01)

For information regarding applications in other mast sections than the above specified, please contact Rutgerson or your local distributor.